



"Award Winning Space Solutions"



Smarter Modular Solutions

A Subsidiary of Vanguard Modular Building Systems

Pentucket Regional School District West Newbury, Massachusetts



"Vanguard Modular exceeded my expectations in every area and helped us meet a time frame that seemed impossible. If the need were to arise, I would have no hesitation about contacting Vanguard again."

Richard O'Shea
Business Manager
Pentucket Regional School District
West Newbury, Massachusetts

Challenge: To accommodate a rapidly growing student population, Pentucket Regional School District required four 900 sq. ft. classrooms to be immediately added to their existing building. Each classroom required fire alarms and comprehensive data and communications wiring.

Modular Solution: Vanguard Modular delivered a complete turnkey solution – including excavation, foundations, modular building design and construction, installation, matching existing school floor level and brick exterior, landscaping and drainage, and providing compatible equipment and connections for existing fire alarm, intercom and computer data lines. The rooms were completed on time and at a fraction of the cost of traditional construction.

[1-800-448-6772 • www.vanguardmodular.com]
[1-877-349-9714 • www.schiavileasingcorp.com]



Modular Solutions

Floor Plan for: Pentucket Regional School District

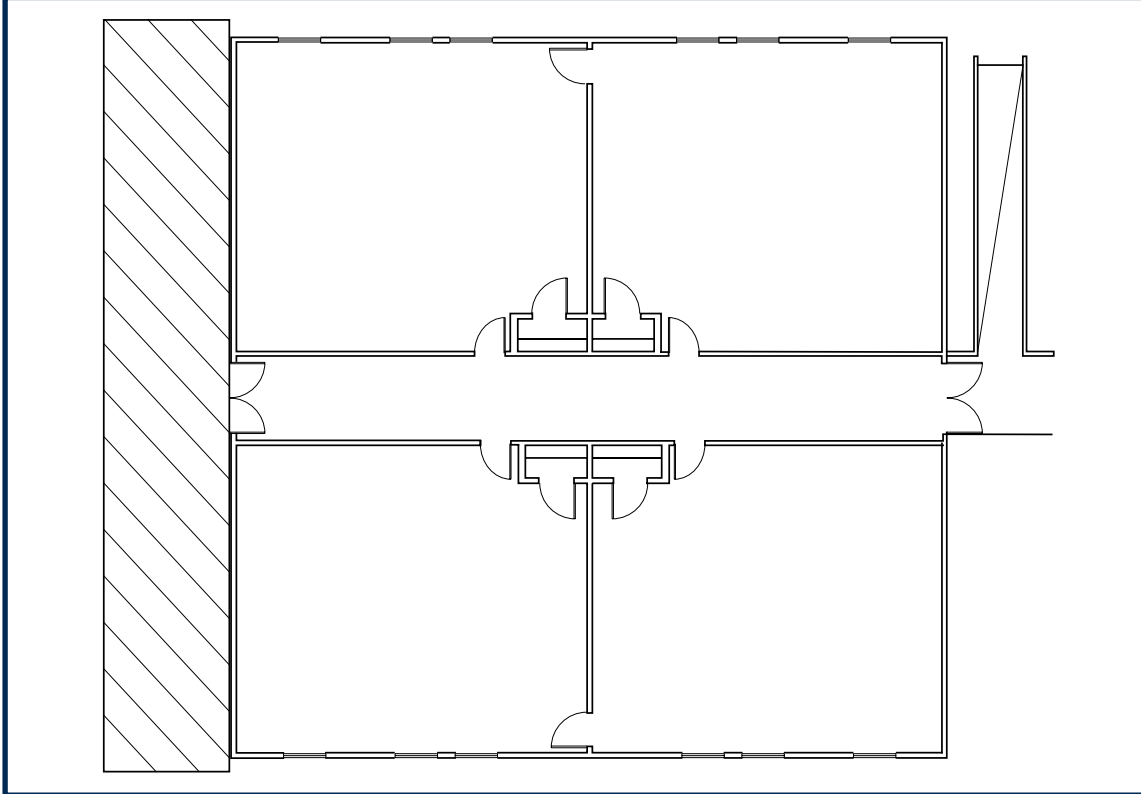

Project Schedule

Date of award.....	April 3
Site construction/building drawings submitted	May 5
Site work begins.....	June 30
Modular building manufacturing completed.....	July 28
Modular building delivered	August 2
Substantial setup completed	August 31
From Start to Finish:	150 Days



Corporate Headquarters
Valleybrooke Corporate Center
100 Lindenwood Drive, Suite 200 • Malvern, PA 19355
800-448-6772 • www.vanguardmodular.com



Schiavi Leasing Corporation
102 Industrial Drive • Oxford, ME 04270
877-349-9714 • www.schiavileasingcorp.com

